

Features

EASILY CONFIGURED TO MEET YOUR NEEDS

FORK OPTIONS

- Load platform
- Fork extensions

POWER OPTIONS

- One-speed winch
- Two-speed winch

BASE

- Standard base

CASTER

- Standard casters

OPTIONS & ACCESSORIES

PRODUCTIVITY

- Load platform
- Fork extensions

POWER

- Two-speed winch

STANDARD FEATURES

MEASUREMENTS

ST™-20

- 6.46 m (21 ft 2.5 in) maximum working height
- Up to 363 kg (800 lb) load capacity

ST™-25

- 7.94 m (26 ft .5 in) maximum working height
- Up to 295 kg (650 lb) load capacity

PRODUCTIVITY

- Use as a single unit, or two or more can be used together to support trusses
- Flat black anodized finish is nearly invisible to audience
- Portable and compact design
- Lightweight, durable aluminum construction
- Single-door access
- Easy set-up with no tools required
- Durable steel forks
- Hand winch locks in place when handle is released
- Easy to transport—no bulky base
- Hold-down mechanism secures carriage during transport
- Position swivel-lock casters

POWER

- One-speed winch
- Reversible winch handle for easy storage



Specifications

MODELS	ST™-20		ST™-25	
MEASUREMENTS	Metric	US	Metric	US
A Height - stowed	2.2 m	6 ft 6.75 in	2.2 m	6 ft 6.75 in
B Length - stowed	64 cm	2 ft 1.25 in	64 cm	2 ft 1.25 in
C Width - stowed	56 cm	1 ft 10 in	56 cm	1 ft 10 in
D Load height minimum	15 cm	6 in	15 cm	6 in
E Ground clearance - centre	5 cm	2 in	5 cm	2 in
Working height - forks up	6.46 m	21 ft 2.5 in	7.94 m	26 ft .5 in
- forks down	5.94 m	19 ft 6 in	7.42 m	24 ft 4 in
PRODUCTIVITY				
Load capacity - at 46 cm load centre	363 kg	800 lbs	295 kg	650 lbs
Length - adjustable forks	70 cm	27.5 in	70 cm	27.5 in
Width - adjustable forks	29-76 cm	11.5-30 in	29-76 cm	11.5-30 in
Fork extensions detached each (l/w/d)	76/5/8 cm; 2 kg	30/2/3 in; 4.5 lbs	76/5/8 cm; 2 kg	30/2/3 in; 4.5 lbs
Fork extensions attached each (l/w/d)	64/5/8 cm; 2 kg	25/2/3 in; 4.5 lbs	64/5/8 cm; 2 kg	25/2/3 in; 4.5 lbs
Weight - adjustable forks	24 kg	52.5 lbs	24 kg	52.5 lbs
Outrigger footprint	1.87 x 2.02 m	73.5 x 79.5 in	1.87 x 2.02 m	73.5 x 79.5 in
Casters	standard casters		standard casters	
POWER				
One-speed winch - average cranks	28 cranks/m	8.5 cranks/ft	28 cranks/m	8.5 cranks/ft
WEIGHT*				
	230 kg	507 lbs	252 kg	555 lbs

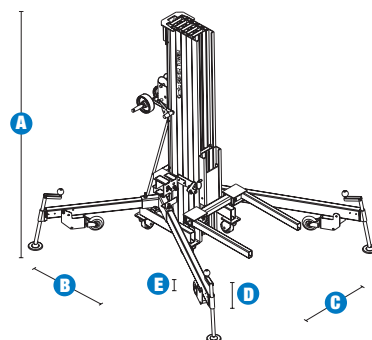

* Weight will vary depending on options and/or country standards.

Genie Europe

Millennium House
Brunel Drive
Newark NG24 2DE
UK
Tel: +44 (0)1476 584333
Fax: +44 (0)1476 584334

Email: AWP-InfoEurope@terex.com

Genie United States

18340 NE 76th Street
P.O. Box 97030
Redmond, WA
USA 98073-9730
Tel: +1 425 881-1800
Fax: +1 425 883-3475

Distributed By:

Effective date: December, 2008. Product specifications and prices are subject to change without notice or obligation. The photographs and/or drawings in this document are for illustrative purposes only. Refer to the appropriate Operator's Manual for instructions on the proper use of this equipment. Failure to follow the appropriate Operator's Manual when using our equipment or to otherwise act irresponsibly may result in serious injury or death. The only warranty applicable to our equipment is the standard written warranty applicable to the particular product and sale and we make no other warranty, expressed or implied. Products and services listed may be trademarks, service marks or trade-names of Terex Corporation, Genie Industries, Inc. and/or their subsidiaries in the U.S.A. and many other countries. All rights are reserved. Terex is a Registered Trademark of Terex Corporation in the U.S.A. and many other countries. Genie is a Registered Trademark of Genie Industries, Inc in the U.S.A. and many other countries. Genie is a Terex Company. Copyright 2008 Terex Corporation

UK

Millennium House
Brunel Drive
Newark NG24 2DE
UK
Tel: +44 (0)1476 584333
Fax: +44 (0)1476 584334

France

10, ZA de la Croix St. Mathieu
28320 Gallardon
France
Tel: +33 (0)2 37 26 09 99
Fax: +33 (0)2 37 26 09 98

Germany

Finienweg 3
28832 Achim/Bremen
Germany
Tel: +49 (0)4202 8852-0
Fax: +49 (0)4202 8852-25

Spain

Gaià 31, Pol. Ind. Plà d'en Coll
08110 Montcada i Reixac
Barcelona
Spain
Tel: +34 93 572 50 90
Fax: +34 93 572 50 91

Scandinavia

Importgatan 17
422 46 Hisings Backa
Sweden
Tel: +46 31 57 51 00
Fax: +46 31 57 90 20

Middle East

Terex Middle East
PO Box 282325, Dubai
U.A.E.
Tel: +971 4 885 8030
Fax: +971 4 885 6364
Email: awp.infome@terex.com

Genie United States

18340 NE 76th Street
P.O. Box 97030
Redmond, WA
USA 98073-9730
Tel: +1 425 881-1800
Fax: +1 425 883-3475

Email: AWP-InfoEurope@terex.com

Distributed By: